

# PILOT OPERATED NON-RETURN VALVE

Series GV2

Cat No GV2 - 01 - 01

## PILOT OPERATED NON-RETURN VALVE - G1/8, G1/4, G3/8, G1/2

### Features

- ❑ Available in two versions
- ❑ Low cracking and closing pressure
- ❑ Bubble tight - elastomer seat
- ❑ Plastic portion can be turned by 360°
- ❑ Teflon pre-coated male taper threads



### Function

Pilot operated non-return valve is used for stopping the cylinder in intermediate position. So long as a pilot signal is applied, air is free to flow to and from the cylinder. When the pilot signal is removed, the valve acts as a conventional non-return valve and prevents air from exhausting from the cylinder, thus stopping movement.

### Technical Specifications

Model	G1/8	G1/4	G3/8	G1/2
Type	Pilot operated non return valve			
Medium	Compressed air - Dry / Lubricated			
Operating pressure range	0.2 - 10 bar			
Ambient Temperature	5° - 60° C			
Applicable tubes	Nylon, Polyurethane			

### Example of circuit

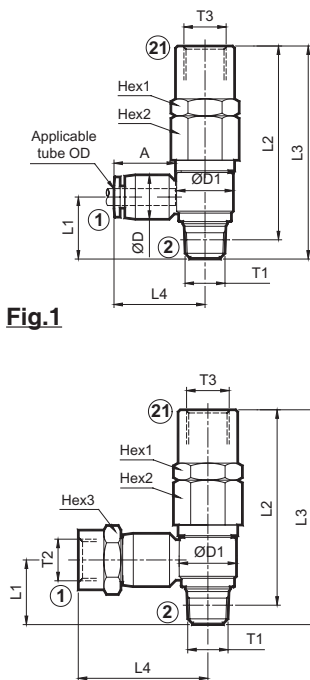
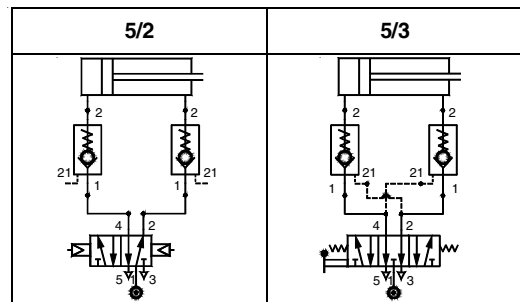

Fig.1

Fig.2

Thread	Thread			Applicable tube OD	A	L1	L2	L3	L4	ØD	ØD1	Hex1	Hex2	Hex3	Flow (lpm) @	Ordering No
	T1	T2	T3													
R1/8	-	-	-	4	15	15	46	52	22	10.5	13.5	14	14	-	225	GV210450
				6	15	15	46	52	23	12.5	13.5	14	14	-	250	GV210650
R1/8	G1/8	-	-	-	-	15	46	52	30	-	13.5	14	14	14	250	GV216050
R1/4	-	-	G1/8	6	15.5	20	52	58	25	12.5	18	17	17	-	400	GV210651
				8	17	20.5	52	58	27.5	15	18	17	17	-	500	GV210851
				10	20	22.5	52	58	32.5	18.5	18	17	17	-	500	GV211051
R1/4	G1/4	-	-	-	-	20	52	58	37	-	18	17	17	500	GV216151	
R3/8	-	-	G1/8	8	17	23	54.5	61	29	15	22	22	24	-	850	GV210852
				10	18	24	54.5	61	34	18.5	22	22	24	-	900	GV211052
R3/8	G3/8	-	-	-	-	24	54.5	61	46.4	-	22	22	24	22	900	GV216252
R1/2	-	-	G1/8	12	20.5	28.5	55.5	63	37.5	21	28	27	27	-	1100	GV211253
				-	-	-	28.5	55.5	63	54	-	28	27	27	27	1100

1 - Inlet, 2 - Outlet, 21 - External pilot

A - Tube insertion length

@ Inlet pressure 6 bar, and pressure drop 1 bar

### How to Order

While ordering Pilot operated non-return valve, mention the ordering number given in the corresponding tables

Subject to change